

SB形

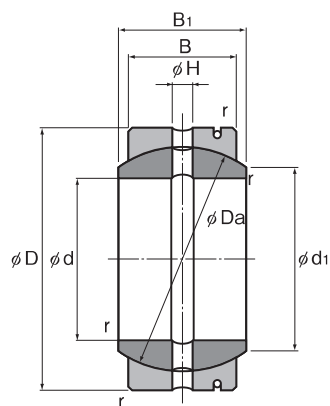

単位:mm

呼び形番	主要寸法								基本定格荷重		質量 kg
	内径 d	外径 D	外輪幅 B	内輪幅 B ₁	d ₁	Da	H	r	C kN	C ₀ kN	
SB 12	12	22	9	11	14	18	1.5	0.5	3.82	95.3	0.019
SB 15	15	26	11	13	17.5	22	2.5	0.5	5.69	142	0.028
SB 20	20	32	14	16	23	28	2.5	0.5	9.22	230	0.053
SB 22	22	37	16	19	25.5	32	2.5	0.5	12.1	301	0.085
SB 25	25	42	18	21	29	36	4	0.5	15.3	381	0.116
SB 30	30	50	23	27	36	45	4	1	24.3	609	0.225
SB 35	35	55	26	30	40	50	4	1	30.6	765	0.3
SB 40	40	62	28	33	44	55	4	1	36.3	906	0.375
SB 45	45	72	31	36	50.5	62	6	1	45.2	1130	0.6
SB 50	50	80	36	42	58.5	72	6	1	61	1530	0.87
SB 55	55	90	40	47	64.5	80	6	1	75.3	1880	1.26
SB 60	60	100	45	53	72.5	90	6	1	95.3	2380	1.7
SB 65	65	105	47	55	76	94	6	1	104	2600	2.05

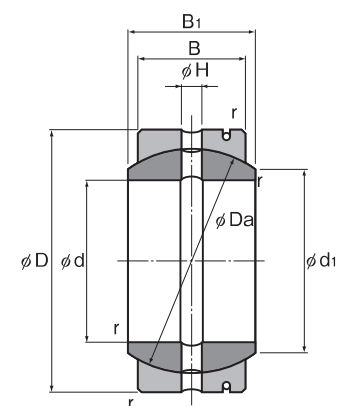

単位:mm

呼び形番	主要寸法								基本定格荷重		質量 kg
	内径 d	外径 D	外輪幅 B	内輪幅 B ₁	d ₁	Da	H	r	C kN	C ₀ kN	
SB 70	70	110	50	58	81.5	100	8	1	118	2940	2.22
SB 75	75	120	55	64	89.5	110	8	1	142	3560	3.02
SB 80	80	130	60	70	97.5	120	8	1	170	4240	3.98
SB 85	85	135	63	74	100.5	125	8	1	185	4640	4.29
SB 90	90	140	65	76	105.5	130	8	1	199	4970	4.71
SB 95	95	150	70	82	113.5	140	8	1	230	5760	6.05
SB 100	100	160	75	88	121.5	150	10	1.5	265	6620	7.42
SB 110	110	170	80	93	130	160	10	1.5	301	7530	8.55
SB 115	115	180	85	98	132.5	165	10	1.5	330	8250	10.3
SB 120	120	190	90	105	140	175	10	1.5	371	9260	12.4
SB 130	130	200	95	110	148.5	185	10	1.5	414	10300	13.8
SB 150	150	220	105	120	166	205	10	1.5	507	12600	17