

SA1形

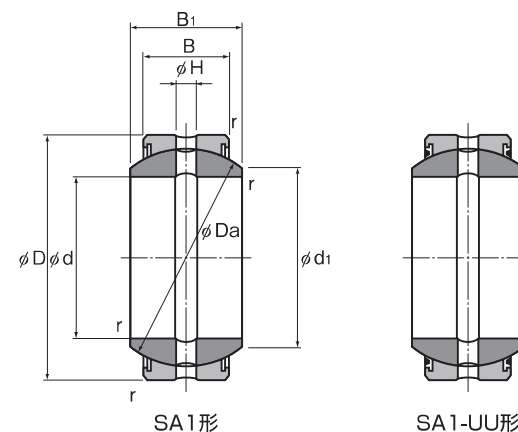
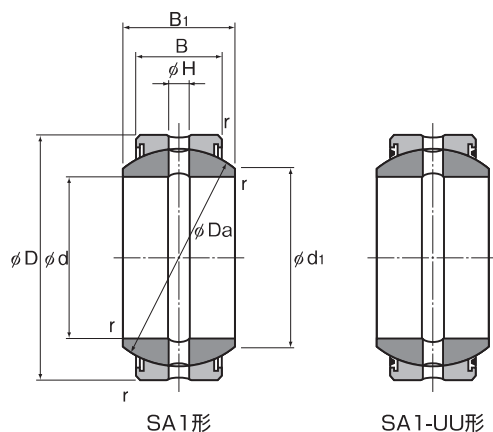

単位:mm

単位:mm

呼び形番		主要寸法								基本定格荷重		質量
標準形	シール形	内径	外径	外輪幅	内輪幅					C	C ₀	kg
		d	D	B	B ₁	d ₁	Da	H	r	kN	kN	
SA1 12	SA1 12UU	12	22	7	10	15	18	1.5	0.3	2.94	74.1	0.017
SA1 15	SA1 15UU	15	26	9	12	18.4	22	2.5	0.3	4.7	117	0.032
SA1 17	SA1 17UU	17	30	10	14	20.7	25	2.5	0.3	5.88	147	0.049
SA1 20	SA1 20UU	20	35	12	16	24.2	29	2.5	0.3	8.23	205	0.065
SA1 25	SA1 25UU	25	42	16	20	29.3	35.5	4	0.3	13.3	334	0.115
SA1 30	SA1 30UU	30	47	18	22	34.2	40.7	4	0.3	17.3	431	0.16
SA1 35	SA1 35UU	35	55	20	25	39.8	47	4	1	22.1	553	0.258
SA1 40	SA1 40UU	40	62	22	28	45	53	4	1	27.5	686	0.315
SA1 45	SA1 45UU	45	68	25	32	50.8	60	6	1	35.3	882	0.413
SA1 50	SA1 50UU	50	75	28	35	56	66	6	1	43.5	1090	0.56
SA1 60	SA1 60UU	60	90	36	44	66.8	80	6	1.5	67.7	1700	1.1
SA1 70	SA1 70UU	70	105	40	49	77.9	92	8	1.5	86.6	2170	1.54

呼び形番		主要寸法								基本定格荷重		質量
標準形	シール形	内径	外径	外輪幅	内輪幅					C	C ₀	kg
		d	D	B	B ₁	d ₁	Da	H	r	kN	kN	
SA1 80	SA1 80UU	80	120	45	55	89.4	105	8	1.5	111	2780	2.29
SA1 90	SA1 90UU	90	130	50	60	98.1	115	8	2	135	3380	2.84
SA1 100	SA1 100UU	100	150	55	70	109.5	130	8	2	169	4210	4.43
SA1 110	SA1 110UU	110	160	55	70	121.2	140	8	2	181	4530	4.94
SA1 120	SA1 120UU	120	180	70	85	135.6	160	8	2	264	6590	8.12
SA1 140	SA1 140UU	140	210	70	90	155.9	180	8	3	296	7410	11.3
SA1 160	SA1 160UU	160	230	80	105	170.2	200	10	3	376	9410	14.4
SA1 180	SA1 180UU	180	260	80	105	199	225	10	3	424	10600	18.9
SA1 200	SA1 200UU	200	290	100	130	213.5	250	10	3	588	14700	28.1
SA1 220	SA1 220UU	220	320	100	135	239.6	275	10	3.5	647	16200	36.1
SA1 240	SA1 240UU	240	340	100	140	265.3	300	10	3.5	706	17600	40.4

注)呼び形番100以上は外輪が2分割タイプです。